

# CROCHET DE CONTREVENT

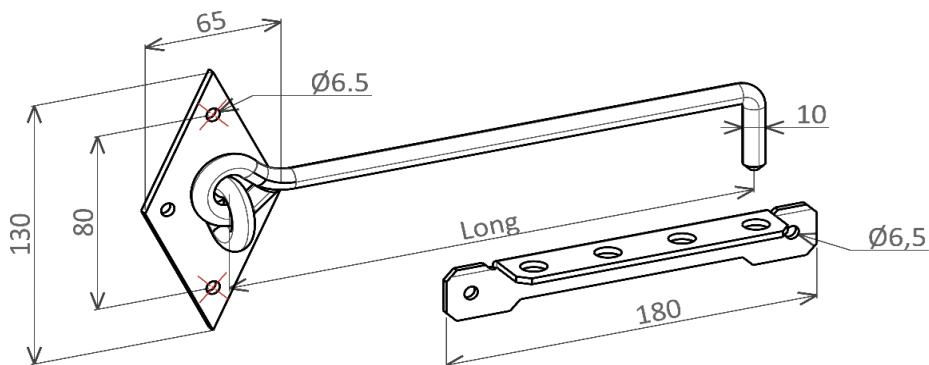
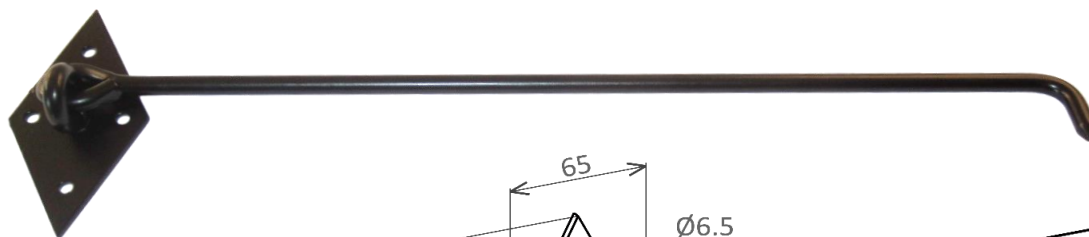

## CROCHET DE CONTREVENT SEULE

référence	Long
80CO1040N	400
80CO1050N	500
80CO1060N	600

## CROCHET DE CONTREVENT + CREMAILLERE

référence	Long
80CU1040N	400
80CU1050N	500
80CU1060N	600

## CREMAILLERE D10 SEULE

référence	Long
80UC3180N	180

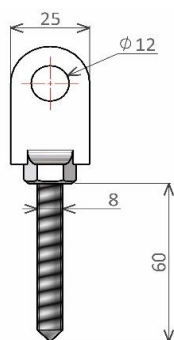

## PITON A VIS

référence
80UCV860N

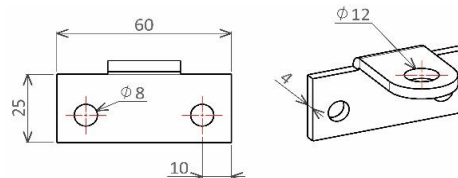

## GACHE CROCHET DE CONTREVENT

référence
80UC2560N

◇ Finition RAL 9005 satiné thermolaquage (voir page 43)  
 ◇ Conditionnement, se référer au tarif (annexe)

TEL. +33 (0)4 50 72 40 49 FAX. +33 (0)4 50 72 49 26  
 contact@brasierindustrie.com